

SEA BORN



Demand Value

Versatile, Affordable, Reliable

Tough, solid built, straight forward.
Sensible boats for your family.



SEA BORN



The family of boats
built by
Composite Research



Sea Born
Offshore
Boats



Sea Born
Tournament
Bay Boats



Sea Born
NX Series
Bay Hybrid



Sea Born
SV Series
Bay Boats



Spyder
Light Tackle
Flats Skiffs



Sundance
Skiffs

SX239 Open
SXS Console (no Front Seat)
Open to Bow
Coffin Box w/ Cushions



Open layout with Coffin Box



Transom Door & Floor Fish Box

SX239 Offshore

The Sea Born SX239 is the first boat in a new series from Composite Research. Building on the impact of the FX25 Tournament Bay introduced in 2013 we have redrawn the modern offshore cockpit.

Gone are the "Euro" transoms with their space robbing layout. The engine, mounted on setback brackets, is moved away from the elegant tumblehome transom creating the cockpit room normally found on a 25 ft. boat. She runs on a Jeff Seyler designed double step hull that gives a 24% reduction in surface drag for better efficiency at cruising speeds.

This boat is offered in 2 interior layouts; the SX239 Open and the SX239 Classic. As the name implies, the Open is a fishing focused boat open from the bow to the stern with a large coffin box ahead of the console. The Classic has a console with large double front seat and a forward U-Lounge with forward facing back rest. Key features on both boats are double 120 qt. fish boxes in the aft cockpit floor, over 5'-9" headroom in the walk in console and a transom door leading to a large molded swim platform.

Check out our huge selection of standard features and then look closely at competitive boats; we did and they do not measure up to the new Sea Born SX239.

SX239 Classic
SXL Console w/ Front Seat
Bow U-Lounge Seating w/
Forward Facing Backrest



Leaning Post and Console w/ Footrest



Walk In Console Head with 5'-9" Interior



Classic layout Bow Seating with Forward Facing Removable Backrest

SX239 Offshore

SPECIFICATIONS	
Length (Hull)	23' - 2"
Length Overall	23'-9"
Beam	8'-7"
Transom Height	25"
Approx. Weight (Dry)	3,850 Lbs.
Approx Wt w/ 250 & Fuel	5,100 Lbs.
Fuel Capacity	93 Gals.
Maximum H.P.	250 H.P.
Dead Rise: Transom	21°
Dead Rise: Mid Step	23°
Dead Rise: Fore Step	25°
Draft	17"
Inside Height	30"



SEA BORN

SX239 Open with SE Package in Sea Foam

SX239 Open
SXS Console (No front Seat)
Open to Bow
Coffin Box w/ Cushions



Room for Large Displays



Side Storage for 3 Rods per Side



Leaning Post w/ Storage & Shelf

STANDARD FEATURES FOR SX239 OPEN AND CLASSIC

- 10 Year Fully Transferable Hull Warranty
- All Composite Construction (No Wood)
- Advanced Fiberglass Stringer System
- 2SG Double Step Hull
- Diamond Yacht Style Non-Skid
- Anchor Locker and Anchor Roller Pulpit
- Anchor Chain Pipe w/ Hinged Lid
- Anchor Chain Binder
- Epoxy Coated Aluminum Fuel Tank
- 62 Quart Aerated Rear Live Well w/ Plexi Lid
- High Speed Livewell Pick Up
- Stainless Steel Thru Hulls
- Brass Sea Cocks
- Raw Water Washdown
- Floor Fish Boxes w/ Gulper Pump Out
- Built-In Swim Platform w/ 3 Step Ladder
- Walk Thru Transom Door
- Cockpit Drain Sumps (Self Bailing Cockpit)
- Stainless Steel Cockpit Drain Covers
- Stainless Steel Rub Rail
- Flush Mount Cleats (4)
- Aft Cleats Hawse Pipe
- Recessed Bow Rails
- SS Cupholders w/ Drains
- Compass - Illuminated
- Forward Coaming Cushions
- Aft Cockpit Pit Coaming Cushions
- 5'-8" Headroom in Console
- Lockable Console Door (Room for Head)
- SX Console Footrest w/ Pad
- Console Wind Shield and SS Grab Rail
- 10 Back-Lit LED Rocker Switches
- 12 V Power Point on Dash
- 7 Interior LED (Blue) Courtesy Lights
- Dual Trumpet Horn
- Dual Battery Switch
- Marine Stereo w/ 4 Speakers
- UPS / MP3 Connections in Glove Box
- Hydraulic Tilt Steering
- Cast Stainless 3 Spoke Wheel w/ Knob
- Touch LED Dome Light in Console Head
- Stainless Steel Wheel with Knob
- Deluxe Leaning Post w/ Folding Footrest
- Leaning Post Backrest & Storage Tray
- Leaning Post Cutting Board / 2 Cup Holders
- Gunwale Rod Holders (3 per side)
- Horizontal Under Gunwale Rod Storage (6)
- Folding Rear Bench Seat (Removable)
- Trim Tabs in Recessed Pockets
- Engine Brand Digital Gauges

SE Package

- All Standard Features above
- Storage LED below Deck & Gunwale
- T-Top with E-Box (Black Canvas)
- LED Map Light (Switchable) Red/White
- LED Spreader Lights (2)
- Fresh Water Washdown
- Underwater Lights
- Extra Rod Holders (6 Total)
- 2 Tone Hull Color - Group 1
- Matching Console Face - Color Grp 1

LE Package

- All Standard Features above
- Storage LED below Deck & Gunwale
- Hard Top with E Box
- LED Map Light (Switchable) Red/White
- LED Dome Courtesy Lights - White (2)
- LED Spreader Lights (3)
- Fresh Water Washdown
- Underwater Lights
- Extra Rod Holders (6 Total)
- 2 Tone Hull Color - Group 1
- Matching Console Face - Color Grp 1
- Matching Hard Top Underside - Color Grp 1
- Mister System

SX239 Classic
SXL Console w/ Front Seat
Bow U-Lounge Seating w/
Forward Facing Backrest



LE Hard Top w/ LED Lights



Transom Door & Swim Platform



SE T-Top E Box w/ LED Map Light

SX239 CLASSIC

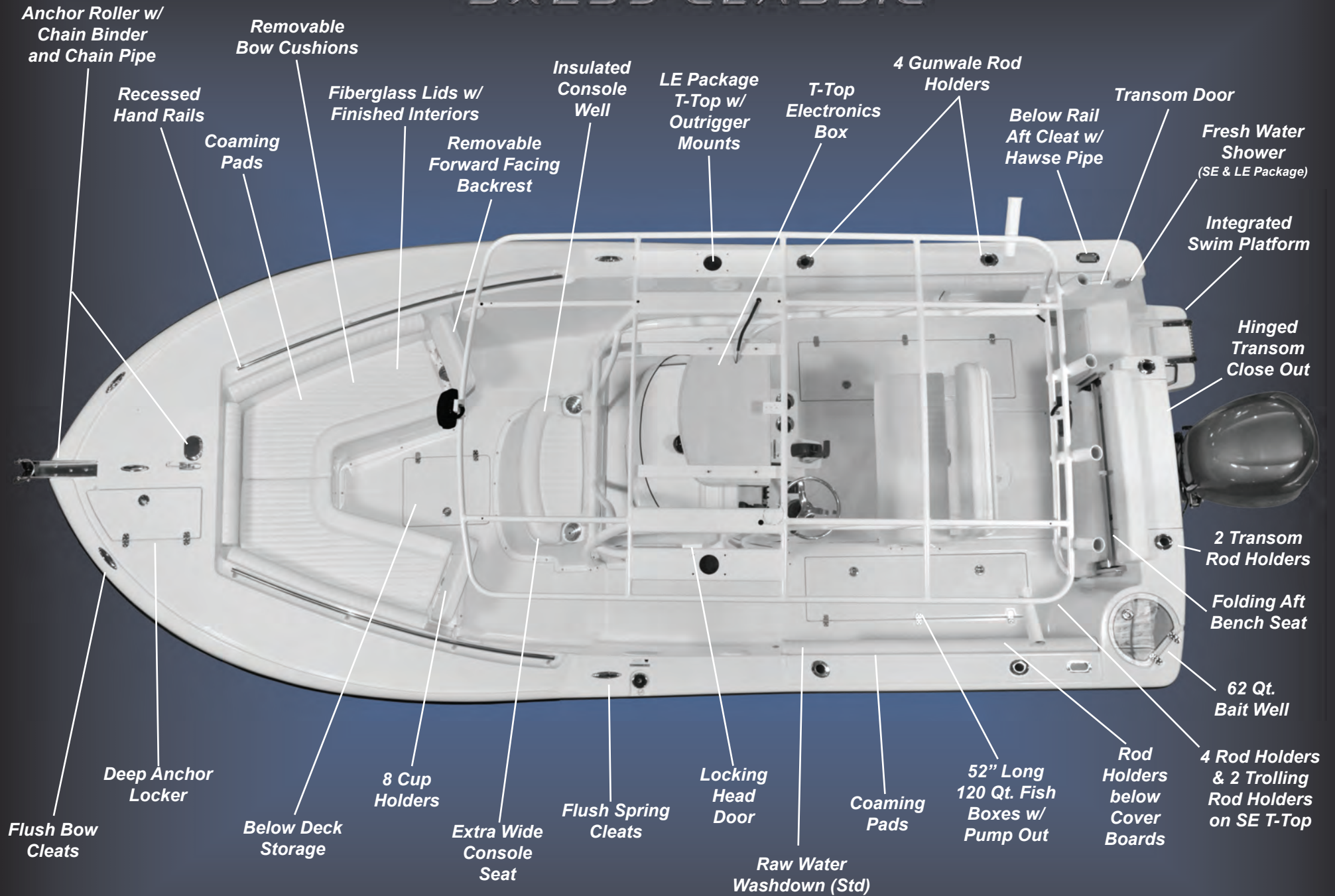

SX239 Classic SE Package Shown

SX239 OPEN

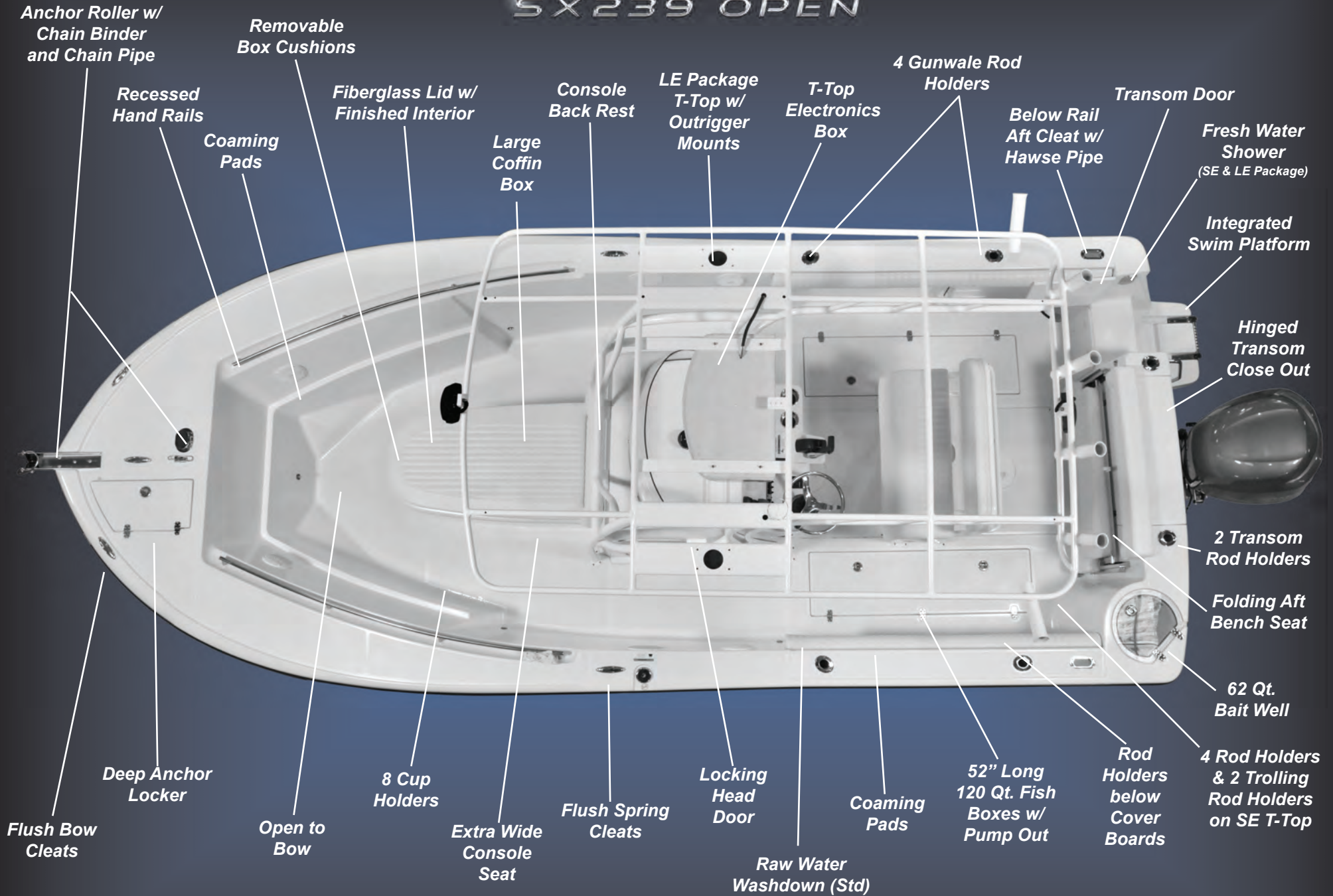

Anchor Roller w/
Chain Binder
and Chain Pipe

Removable
Box Cushions

Recessed
Hand Rails

Coaming
Pads

Fiberglass Lid w/
Finished Interior

Large
Coffin
Box

Console
Back Rest

LE Package
T-Top w/
Outrigger
Mounts

T-Top
Electronics
Box

4 Gunwale Rod
Holders

Below Rail
Aft Cleat w/
Hawse Pipe

Transom Door

Fresh Water
Shower
(SE & LE Package)

Integrated
Swim Platform

Hinged
Transom
Close Out

2 Transom
Rod Holders

Folding Aft
Bench Seat

62 Qt.
Bait Well

4 Rod Holders
& 2 Trolling
Rod Holders
on SE T-Top

Rod
Holders
below
Cover
Boards

52" Long
120 Qt. Fish
Boxes w/
Pump Out

Coaming
Pads

Raw Water
Washdown (Std)

Locking
Head
Door

Flush Spring
Cleats

Extra Wide
Console
Seat

8 Cup
Holders

Open to
Bow

Deep Anchor
Locker

Flush Bow
Cleats

SX239 Open SE Package Shown



SEA BORN



FX25 Tournament

The Sea Born FX25 is a completely new boat from Composite Research. It is based on a stepped hull designed by renowned architect Jeff Seyler. We started with a blank slate. After looking at every boat on the market today and noting every feature you requested, we designed it from the hull up.

The new stepped hull reduces wetted surface by over 20% resulting in better fuel efficiency at cruise and a faster top end speed. An added advantage is a super quick time-to-plane and much lower wakes. A 10" Hydraulic Jack Plate and Trim Tabs are standard. The FX25 will run over 60 mph at wide open throttle with a 300 HP engine.

The full forward flare and wide 105" beam enhances the impeccable styling of the transom tumblehome and molded engine bracket. The fully enclosed sportfish style transom with standard coaming bolsters opens the cockpit up for all around stand up fishing action.

This stylish and roomy boat is loaded with fishing features for every angler and has plenty of cushioned seating for family duty as well.



Molded Sea Chest with Hi Speed SS Strainer



Close-up of Hull Step



Florida Flair Bow



Sportfish Style Fully Enclosed Transom with Molded Engine Bracket



Cored Hull Sides for Superior Strength, Finish & Stiffness

FX25 Tournament

SPECIFICATIONS

Length	24' - 11"
Beam	105"
Transom Height	25"
Approx. Weight	2,850 Lbs.
Fuel Capacity	75 Gals.
Maximum H.P.	300 H.P.
Recommended H.P.	250 H.P.
Dead Rise	17°
Draft	11"
Inside Height	22"



Alpha Layout

Bow Release Well Aerated
Sportfish Stern Well Aerated
Alum Leaning Post w/
Cooler/Storage Tray



Back Lite LED Rocker Switches



Side Storage for 4-11 ft & 4-7 ft Rods



11 Tackle Bins (4) in Console Face

Standard Features

Hand-Laid Bi-Axial Fiberglass
Aluminum Backing Plates in glass
Large Anchor Locker
Forward Release Well - 65 Gal
Optional Below Deck LED Lights
Optional Cushions & Bolster for Lounge
Gas Shocks on Rod Locker Lids
Cast Net Well in Floor (5 Gal)
Console Insulated Well (38 Qt)
Removable Wind Shield
Hydraulic Steering
Deluxe Wheel with Knob
10 Switch Electrical Panel
Resettable Circuit Breakers
Glove Box
Gunwale SS Flush Rod Holders (4)
Side Box holds 4-11 ft & 4-7 ft Rods
Raw Water Wash Down
Sportfish Style Transom
1100 GPH Bait & Release Pumps (2)
1000 GPH Bilge Pump
Rigid Rub Rail w/ Stainless Steel Insert
Choice of Colors
Trim Tabs Standard

Cored Hull Sides and Deck
Self Bailing Deck
Flush Stainless Cleats - 5
Huge Fore Deck Storage - 18 Sq. Ft.
Front U Shaped Lounge
Locking Rod Storage (8 rods) forward
LED Lights in Rod Lockers
NXL Console
Tackle Bins (3) in Console Face
Fold Down Console Hand Rail
Tilt Steering Available
SS Rod Holders on Console (6)
Back Lite LED Rocker Switches
Power Point on Dash
LED Courtesy Lights (6)
Side Rod Boxes with Toe Rail & Shelf
Aft Coaming Bolsters Standard
Optional Fresh Water Wash Down
Optional 48" Fold Down Bench Seat
Bench Seat is Removable
Bronze Sea Cocks
Sea Chest for Water Pick Ups
Hydraulic Jack Plate Standard
Transom Well Lid has Cutting Board



Optional 48" Fold Down Bench Seat mounts along the transom and is easily removed



Bravo Layout

Bow Release Well Aerated
Sportfish Stern Well Fish Box
Fiberglass Leaning Post w/
Aerated Bait Well



Huge Fore Deck Storage - 18 Sq. Ft.



Hydraulic Tilt Steering Option



Cast Net Well in Floor (5 Gal)

SEA BORN FX25

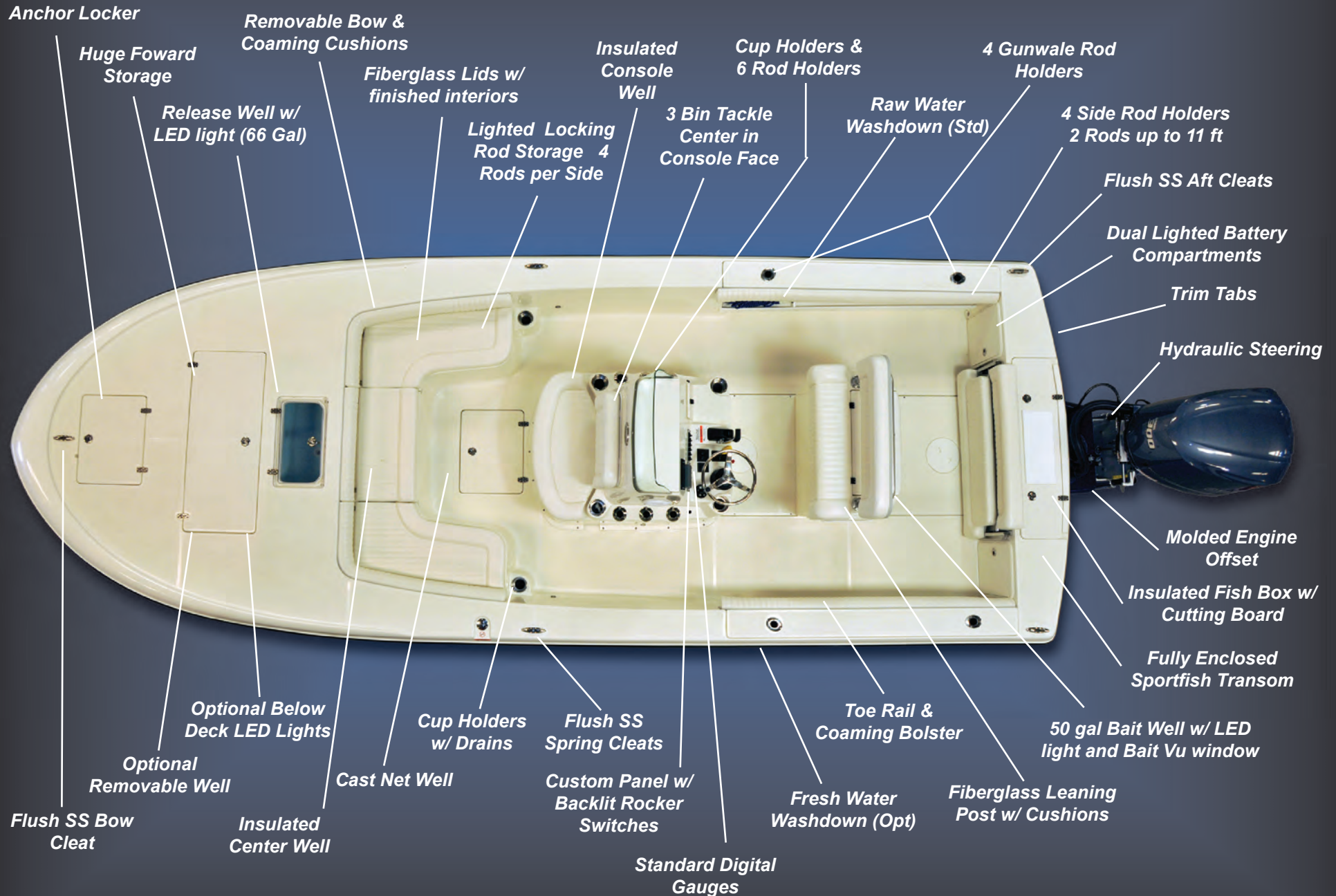



Leaning Post with Bait-Vu Window



Leaning Post Bait Well - 50 Gal. w/ LED



45" Fish Box in Transom

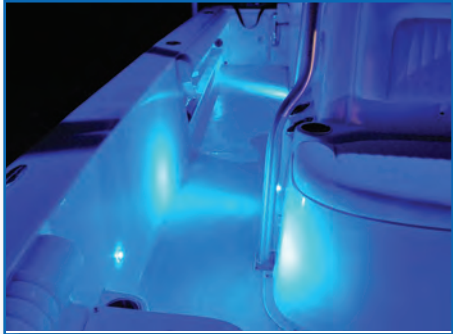

Interior LED Courtesy Lights



Courtesy Lights in Leaning Post Toe Rail



Forward U Lounge w/ Cushions Removed



Optional Hard Top w/ Rod Holders, E-Box, Courtesy & Map Lights, Console Rod Grommets



Optional below deck Storage Lights



Storage for 4 - 6 ft Rods each side

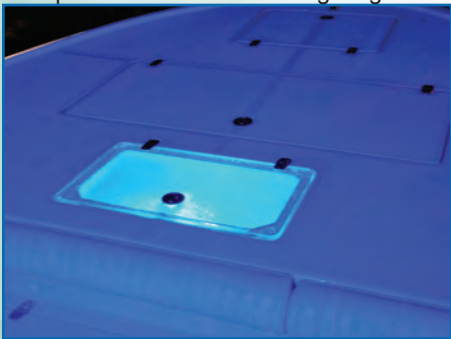

Foward Release Well w/ LED - 66 Gal.



Lids Finished both sides w/ Gas Shocks



Storage Shelf in Side Rod Box



LED Lights under Side Rod Box Coaming



Insulated Well under Console Seat



Insulated Well in center of U Lounge



Large Transom Hatch to access Pumps



Bronze Sea Cocks & SS Thru-Hulls 14

NX Boats

What is the boat of the future? It will run offshore with ease. It will have a shallow draft to fish the back bays. It will get great fuel mileage, measured as miles per gallon not gallons per mile. The future is now.

The new Sundance NX Series boats are here today. The NX boats have a 38 degree entry to cut through heavy chop for serious off shore duty. The hull transitions to a long planing pad with a 7 degree transom and a notched pocket tunnel for incredible fuel efficiency. And all the NX Boats draft 9 inches or less.

We offer many colors using premium Hi-Definition Gel Coats for colors that hold their gloss. You can even order your own custom colors. Rigid rub rail with stainless steel insert is standard. We have loaded the boats with features like hydraulic steering on the 21 foot and larger boats. All have stainless steel flush pull-up cleats, 10-micron fuel filters and waterproof circuit breakers. The entire boat is foam insulated for sound and temperature control.

A closer inspection reveals more attention to the details such as windshield and console handrails are rigged with quick attachments so they can be removed, allowing boat and trailer to clear a standard garage door. In the cockpit, the gunwale-mounted rod holders are equipped with drainage tubes to prevent water from ending up in the bilge. All the boats have multiple options for bait wells, fish ice boxes or live release wells.

And all our boats are backed by a comprehensive 10 Year Transferable Limited Warranty.

The NX Series - true hybrid inshore offshore boats the NeXt generation.



Pale Lady Yellow	Ice Blue	Sea Foam	Platinum	Sun White (standard)
Jet Black	Steel Blue	Admiral Blue	Red	Moss green



Hard Top Mister System



Hard Top LED Lights

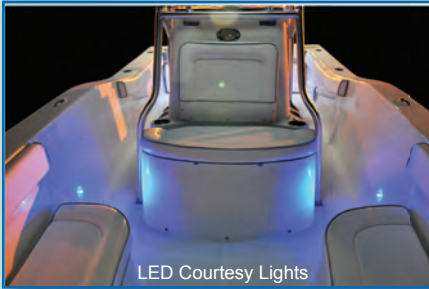

LED Courtesy Lights



Rigid Rub Rail with Stainless Insert



Optional Helm Station & Fresh Water Sink

15



Optional Tackle Station NX25 NX23



Optional Front & Rear Bolsters



NXL Console



Anchor Locker



Front Storage



Leaning Post



NX25 aft lounge

PREMIUM FEATURES

- ALL COMPOSITE-NO WOOD construction
- Foam Injected Fiberglass Stringer System
- Cored Molded Non-Skid Inner Liners
- 316 grade Stainless Steel Fasteners
- 10 YEAR Transferable Warranty
- Marine Grade Tinned Wire
- Hi-Def Gel Coats by HK Research
- Circuit Breaker Electrical Protection
- Hand Laid Hulls and Vacuum Infused Lids



NX25

SPECIFICATIONS

Length	25' - 1"
Beam	99"
Transom Height	25"
Approx. Weight	2,735 Lbs.
Fuel Capacity	72 Gal.
Maximum H.P.	300 H.P.
Recommended H.P.	250 H.P.
Dead Rise	7°
Draft	9"
Inside Ht. (Stern/Bow)	24 / 30"



Shown with standard NXW Console and standard Leaning Post w/ Rod Holders



Shown with standard NXW Console and Leaning Post and optional T-Top

feature highlights

- Rub Rail w/ S.Steel Insert
- Optional Coaming Cushions
- Locking Bow Compartment
- Large Anchor Locker
- Flush Bow Cleat
- Built-In Step
- NXW Walk-In Console
- Cushioned Jump Seats
- Insulated Wells under Seats
- Flush Spring Cleats
- 6 Gunwale Rod Holders

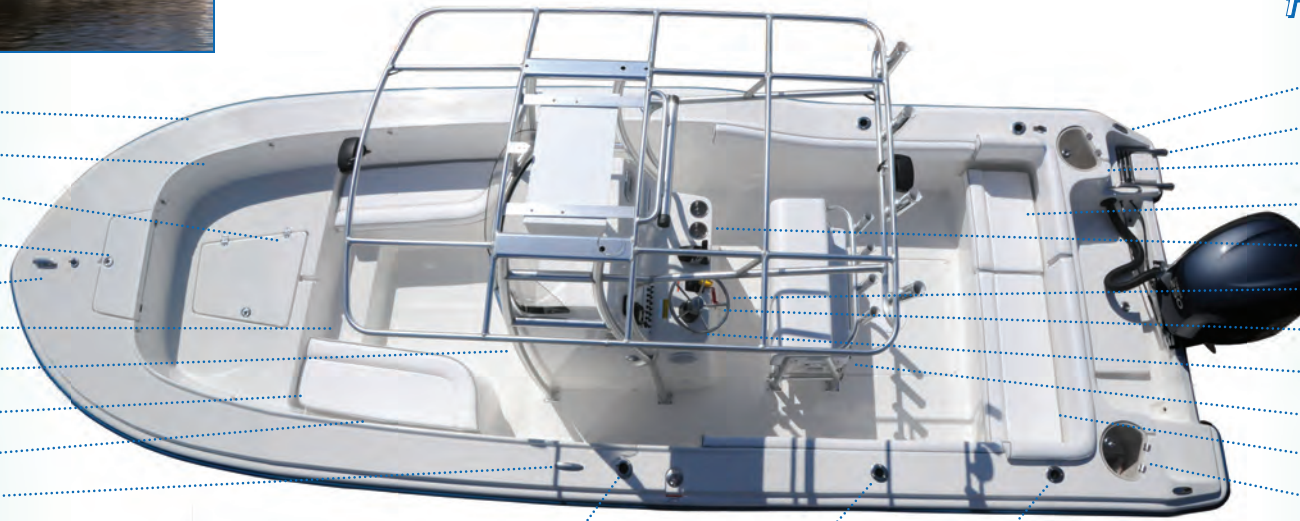

- Flush Aft Cleats
- Fold Down Swim Ladder
- Round Insulated Bait Well
- Aft Lounge & Bolsters
- Glove Box & Cup Holders
- Hydraulic Steering
- Switch Panel w/ breakers
- Digital Gauges
- Leaning Post
- 120qt Insulated Fish Box
- Round Insulated Bait Well



NXW Walk-In Console



NXW Walk-In Console
(view in door with
curtain removed)

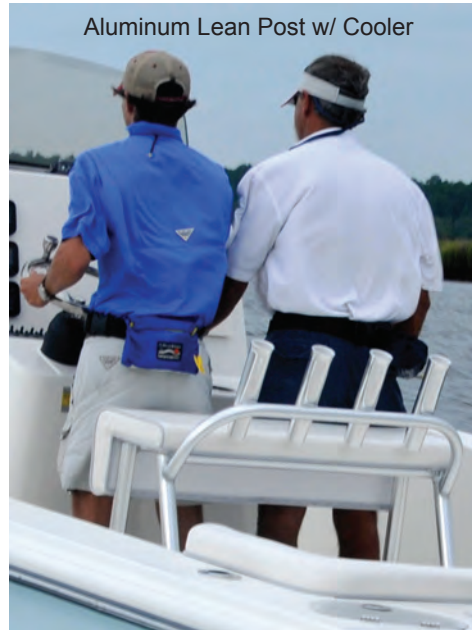

Aluminum Lean Post w/ Cooler

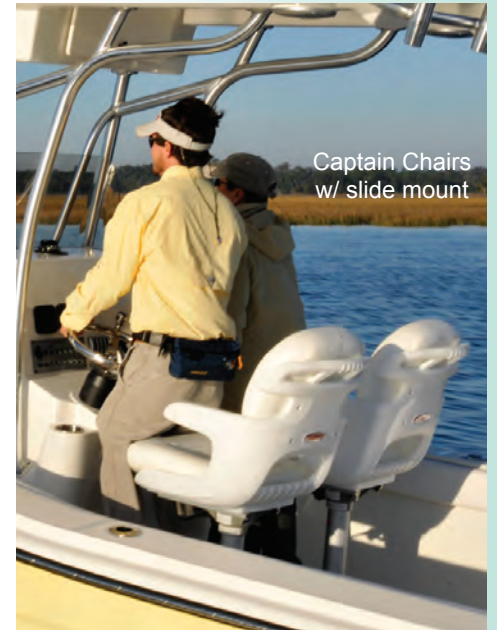

Captain Chairs
w/ slide mount



Isinglass enclosure

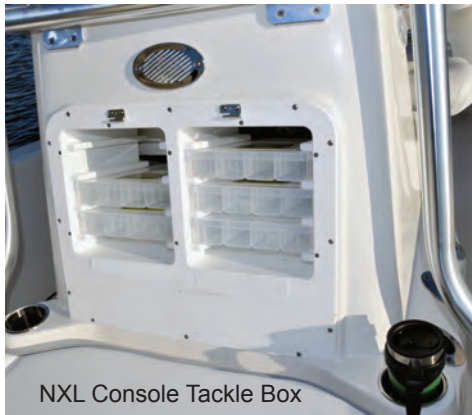

NXL Console Tackle Box

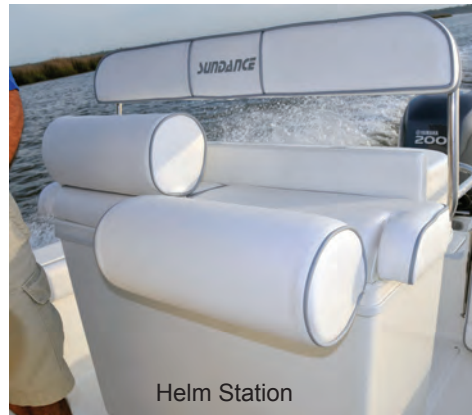

Helm Station



Folding Jump Seats



Hard Top



Front Deck Bolsters,
Cushions, Sun Pad



NXL Console



NX23 Fish Box

NX23

SPECIFICATIONS

Length	23' - 1"
Beam	99"
Transom Height	25"
Approx. Weight	2,475 Lbs.
Fuel Capacity	72 Gals.
Maximum H.P.	250 H.P.
Recommended H.P.	200 H.P.
Dead Rise	7°
Draft	9"
Inside Ht. (Stern/Bow)	24"/30"

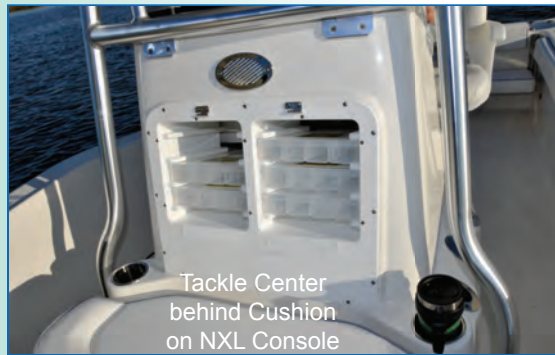

Shown below with optional NXW Walk-In Console and standard Alum Leaning Post

feature highlights



NX21

Shown with NXL Console and optional Alum Leaning Post w/ rod holders



SPECIFICATIONS

Length	21' - 1"
Beam	97"
Transom Height	25"
Approx. Weight	1,850 Lbs.
Fuel Capacity	45 Gals.
Maximum H.P.	150 H.P.
Recommended H.P.	115 H.P.
Dead Rise	7°
Draft	9"
Inside Ht. (Stern/Bow)	20" / 27"



feature highlights

Shown with standard NXL Console with Front Seat and Flip Cooler Seat



NX19

SPECIFICATIONS

Length	18' - 10"
Beam	90"
Transom Height	20"
Approx. Weight	1,475 Lbs.
Fuel Capacity	29 Gals.
Maximum H.P.	115 H.P.
Recommended H.P.	90 H.P.
Dead Rise	7°
Draft	7"
Inside Ht. (Stern/Bow)	19 / 23"



Shown below with standard NXS Console and optional Leaning Post

Aztec Gold color

Shown below with Standard NXS Console and optional Leaning Post

feature highlights

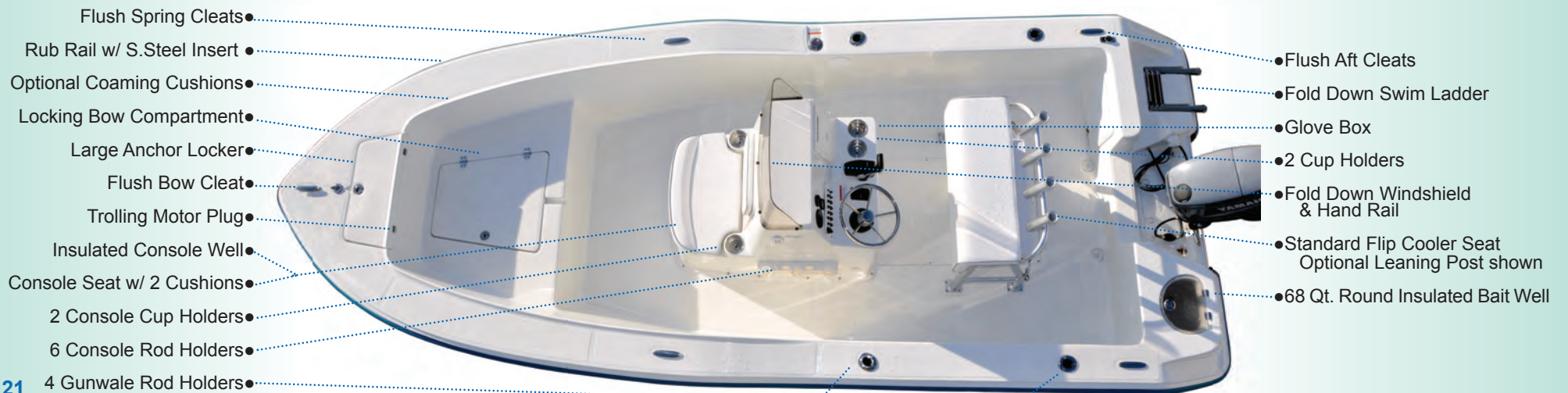

NX17



Shown above with standard NXS Console and Flip Cooler Seat

SPECIFICATIONS	
Length	17' - 2"
Beam	90"
Transom Height	20"
Approx. Weight	1,350Lbs.
Fuel Capacity	29 Gals.
Maximum H.P.	90 H.P.
Recommended H.P.	70 H.P.
Dead Rise	7°
Draft	7"
Inside Ht. (Stem/Bow)	19 / 23"



Admiral Blue

feature highlights

Shown below with Standard NXS Console and optional Leaning Post

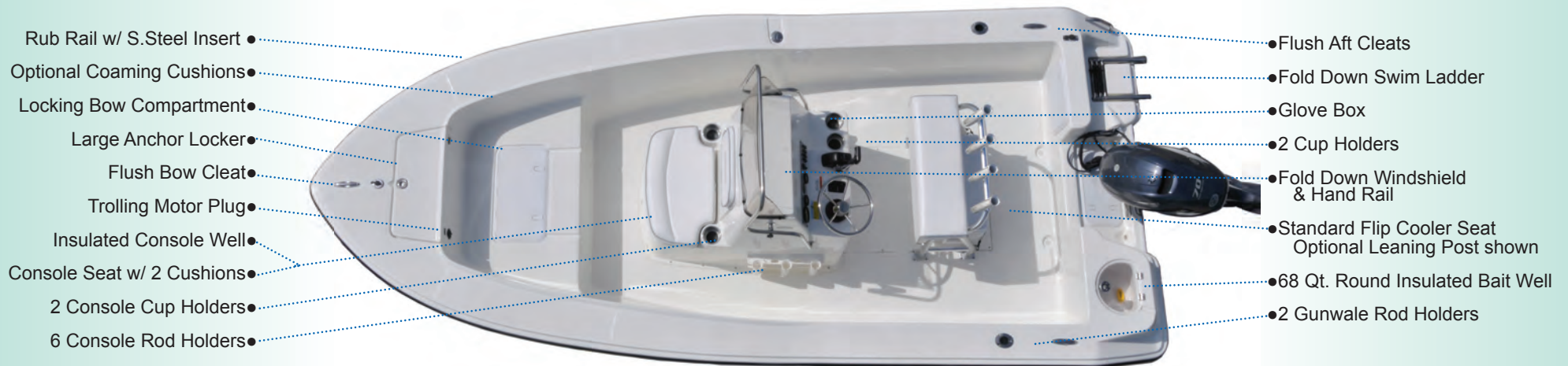

SV Boats



Master patterns cut by robotic CNC machines

Want the most versatile bay boat on the market? The Sundance SV Series center console boats are for you. These boats are adaptable to both fresh water and saltwater and can be used inshore or offshore. The aggressive 17 to 19 degree dead rise hulls have 2 lifting strakes and a wide reverse chine. This strikes a good balance between rough water performance and shallow draft.



The hull has a small air step on the keel directly below the console and a long planing pad to give you quick hole shots with very little bow lift. The long planing pad keeps the boat on top of the water for a shallower running draft.

We build with proven all composite materials including urethane core transoms, molded fiberglass stringers and cored decks. There is no wood used anywhere in the boat. Our hatches are resin infused for precision lay up. The whole boat is foam insulated for sound and temperature control and makes her virtually unsinkable. We back our boats with a 10 Year Transferable Limited Warranty.



Stainless steel thru-hulls & brass seacocks

The wider beams and higher freeboard make for a completely dry and self bailing deck. These boats are a fisherman's dream with large casting platforms, multiple live well options, rod holders and storage options.

If you are looking for a bay - offshore fish boat that can handle a tournament or a family outing, take a close look at the Sea Born SV Series.



Admiral Blue color

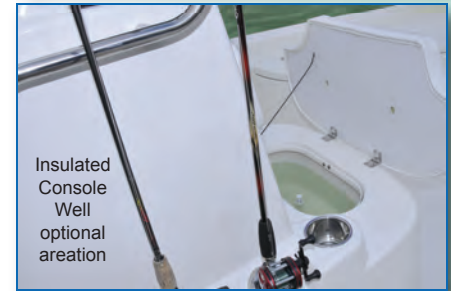
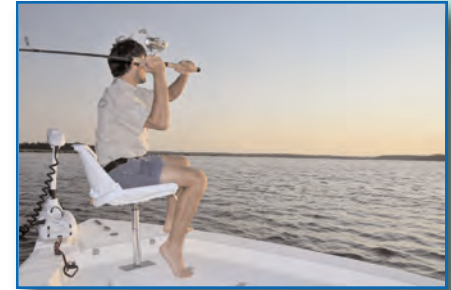

Insulated Console Well optional aeration



Flush Mount Cleat

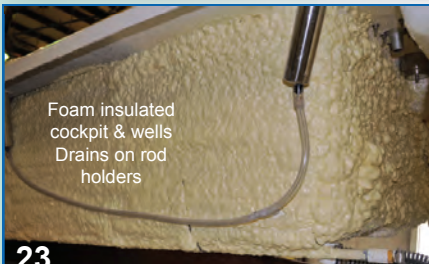

Foam insulated cockpit & wells
Drains on rod holders



PREMIUM FEATURES

- **ALL COMPOSITE-NO WOOD construction**
- **Foam Injected Fiberglass Stringer System**
- **Cored Molded Non-Skid Inner Liners**
- **316 grade Stainless Steel Fasteners**
- **10 YEAR Transferable Warranty**
- **Marine Grade Tinned Wire**
- **Hi-Def Gel Coats by HK Research**
- **Circuit Breaker Electrical Protection**
- **Hand Laid Hulls and Vacuum Infused Lids**



SV231

SPECIFICATIONS

Length	23' - 1"
Beam	98"
Transom Height	25"
Approx. Weight	2,150 Lbs.
Fuel Capacity	72 Gals.
Maximum H.P.	250 H.P.
Recommended H.P.	200 H.P.
Dead Rise	19°
Draft	14"
Inside Height	22"



Platinum color



Shown below with standard NXS Console and Optional Leaning Post

feature highlights

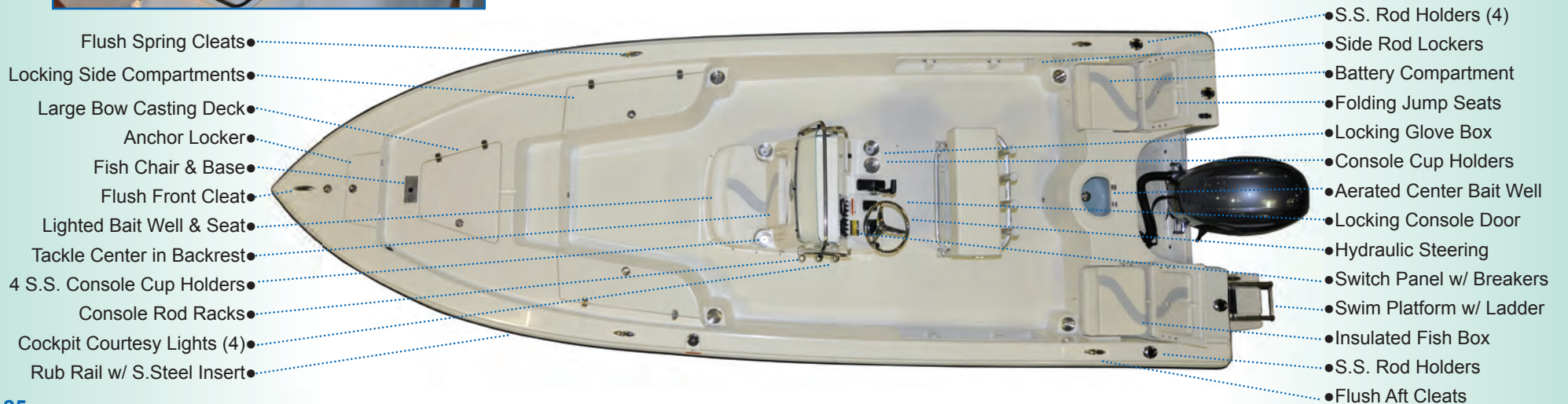

SV211



Ice Blue color

SPECIFICATIONS	
Length	20' - 5"
Beam	98"
Transom Height	25"
Approx. Weight	1,850 Lbs.
Fuel Capacity	45 Gals.
Maximum H.P.	200 H.P.
Recommended H.P.	150 H.P.
Dead Rise	17°
Draft	12"
Inside Height	20"



feature highlights

Shown below with Optional SV Console and Leaning Post

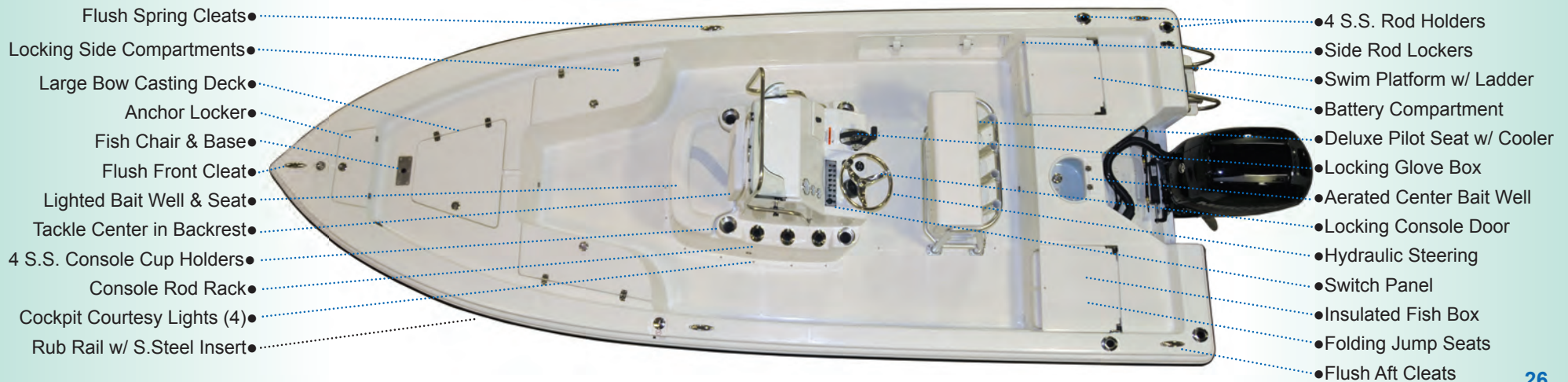

SV19

SPECIFICATIONS

Length	18' - 6"
Beam	90"
Transom Height	25"
Approx. Weight	1,450 Lbs.
Fuel Capacity	40 Gals.
Maximum H.P.	150 H.P.
Recommended H.P.	115 H.P.
Dead Rise	17°
Draft	11"
Inside Height	19"

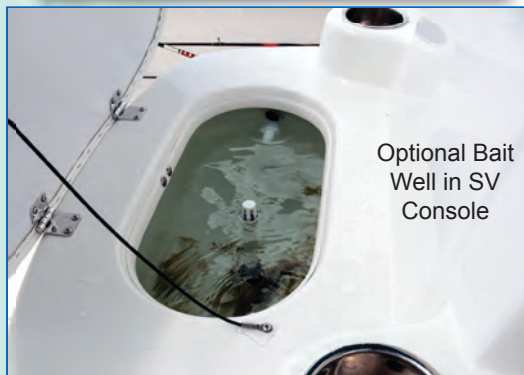

Shown below with standard SV Console and Basic SS Pilot Seat & Cooler

feature highlights

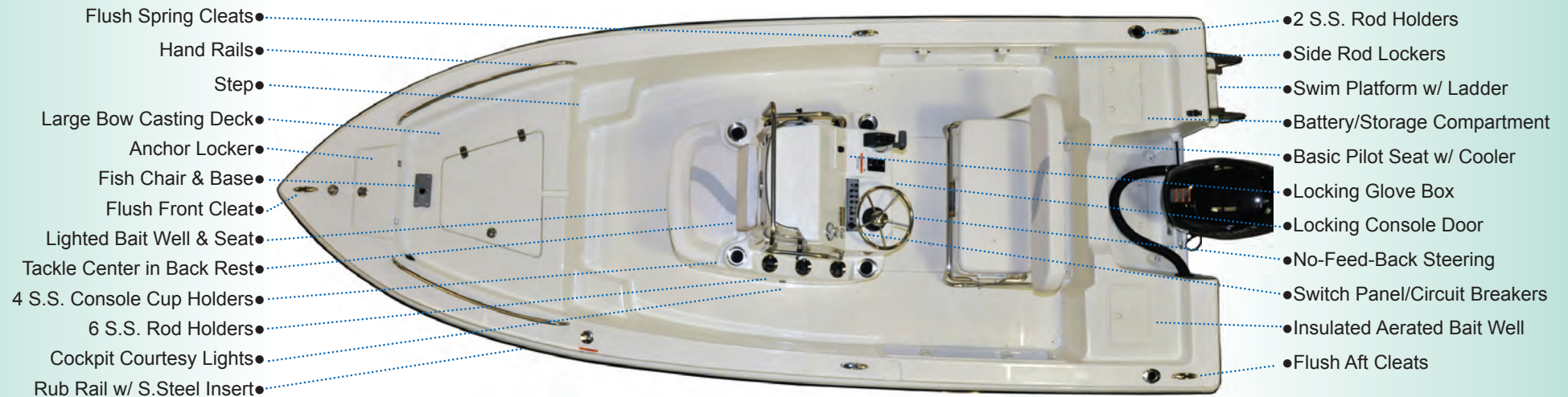

SV17



Pale Lady Yellow color

Shown above with standard FB Console and Flip Cooler Seat

SPECIFICATIONS	
Length	17' - 1"
Beam	90"
Transom Height	20"
Approx. Weight	1,250 Lbs.
Fuel Capacity	34 Gals.
Maximum H.P.	115 H.P.
Recommended H.P.	90 H.P.
Dead Rise	17°
Draft	11"
Inside Height	18"



SV171 uses FB Console

feature highlights

Shown below with standard FB Console and Flip Cooler Seat and optional Cooler and 2 Cushions in front of Console

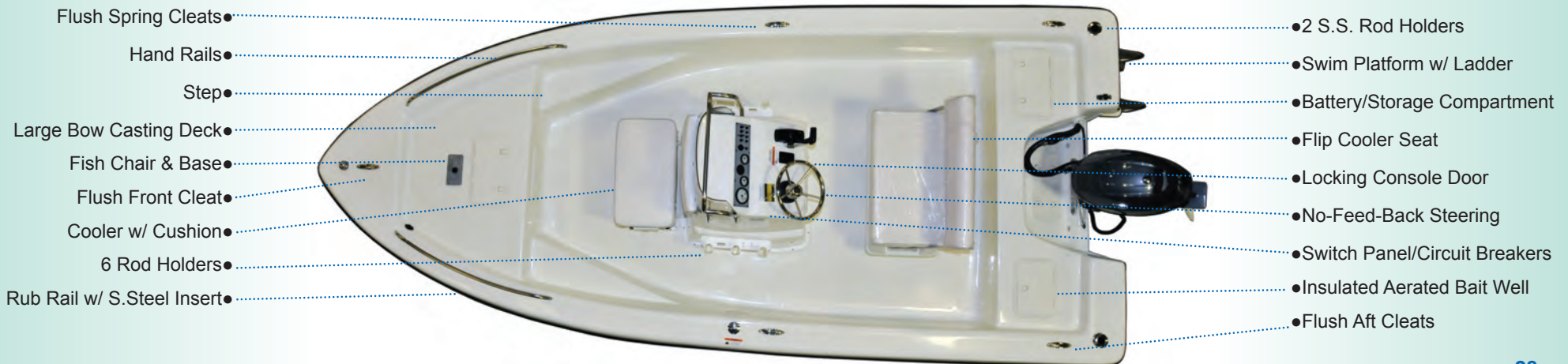

Sea Born Specifications	SV17	SV19	SV211	SV231	NX17	NX19	NX21	NX23	NX25	FX25	SX239
Fishing Hardware & Plumbing											
Port Bait Well (Qts)	40	40			48	48		84	84		62
Stbd Bait Well (Qts)								84	84		
Center Bait Well (Qts)			48	62			84				
Port Fish Box (Qts)			48	48			100				
Center Fish Box (Qts)							100	120			
Fore Deck Release Well (qts)										264	
Transom Fish Box (Qts)										80	
Cockpit Floor Fish Boxes											Z-120
Insulated Console Well (Qts)		32	32	32	32	32	32	32		32	76
Coffin Fish Box (Qts)											160
Steering											
No-Feed-Back Steering	S	S			S	S					
SS Steering Wheel (DIA.)	15	15			15	15					
Hydraulic Steering	O	O	S	S	O	O	S	S	S		
Hydraulic Steering W/ Tilt Steering	O	O	O	O	O	O	O	O	O	S	S
SS Steering Wheel w/ Knob (DIA.)			13	13			13	13	13	13	13
Hydraulic Hose bulkhead strain reliefs			S	S			S	S	S	S	S
Engine Control Cables in rigging sleeve	S	S	S	S	S	S	S	S	S	S	S
Electrical & Plumbing Systems											
Bow Light Bi Color	S	S	S	S	S	S	S	S	S		
LED Nav Lights on Hard Top option				S			S	S	S	S	S
LED Bow Lights Integrated into SS Run Rail										S	S
Stern Light	S	S	S	S	S	S	S	S	S	S	S
Trolling Wire Kit (6 AWG)	S	S	S	S	S	S	S	O	O	O	O
Battery Selector Switch	O	O	O	O	O	O	O	O	S	S	S
Auto Bilge Pump - gph (Standard)	500	500	1100	1100	500	500	1100	1100	1100	1100	1100
Auto Bilge Pump gph (2nd pump auto only)				O			O	O	O	O	O
Aerator Pump No. 1	500	500	500	500	500	500	1000	1000	1000	1000	1000
Aerator Pump No. 2			O	O			O	O	O	O	O
Aerator Hi-Speed PickUp	S	S	S	S	S	S	S	S	S	S	S
Aerator Sea Cock (bronze)	S	S	S	S	S	S	S	S	S	S	S
Raw Water Wash Down System			O	O			O	O	O	S	S
Fresh Water Sink w/ Sprayer								O	O	O	O
Cockpit Courtesy Lights (Blue LED)	S	S	S	S	O	O	S	S	S	S	S
Baitwell Lights (Blue LED)	O	S	S	S	O	O	S	S	S	S	S
Rails & Tops											
Bimini Top w/ Boot	O	O	O	O	O	O	O	O	O		
Tee Top			O	O			O	O	O	O	O
Tee Top Electronics Box			O	O			O	O	O	O	O
Tee Top LED Map Light			O	O			O	O	O	O	O
Hard Top			O	O			O	O	O	O	O
Hard Top Mister System			O	O			O	O	O	O	O
Hard Top 4 Rod Rack			O	O			O	O	O	O	O
Hard Top Top Gun Outrigger Bases			O	O			O	O	O	O	O
Covers & Upholstery											
Front Deck Sun Pad	O	O	O	O	O	O	O	O	O		
Front Deck Bolsters					O	O	O	O	O	O	S
Mid-Ship Deck Bolsters							O	O	O	O	O
Rear Cockpit Bolsters							O	O	S	S	S

S = Standard O = Optional Confirm all specification and options with your Dealer prior to purchase.
A = FX25 Alpha Package, B = FX25 Bravo Package, Op = SX239 Open, CL = SX239 Classic



SV side Rod Lockers



Deluxe Pilot Seat w/ 5 position backrest



Tackle Bins behind Console Cushion



Console Baitwell w/ LED light



SV17 Front Deck w/ tackle box



SV211 Front Deck



Courtesy Lights

Authorized Dealer



www.seabornboats.com

6131 Sundance Rd, Blackshear, GA 31516 912-449-0033 Fax: 912-449-0038 Email: info@seabornboats.com

Sea Born Boats, a division of Composite Research, Inc. continually strives to improve and enhance our products. We reserve the right to change, discontinue or alter specifications, models, features, equipment or prices without notice or incurring any obligations. Some photographs in this brochure may feature boats with optional installed equipment. Some options may conflict with other options. Specification and measurements are approximate and subject to variances. All Sea Born Boats are built to meet or exceed U.S. Coast Guard requirements at time of manufacturer. Sundance, Sea Born and Spyder are trademarks of Composites Research, Inc. All Rights Reserved. Revised January 1, 2014. Confirm all specification and options with your Dealer prior to purchase.